

# CONVEYOR COMPONENTS



**PULLEYS | LAGGING | IDLERS | IMPACT BEDS  
MAGNETIC SEPARATORS | TAKE-UPS**



# Drum Pulleys



All Douglas drum pulleys feature our exclusive single piece rolled rim, solid steel pipe or tubing design that ensures long-life, durability and helps ensure proper belt tracking.

One piece solid steel rims and end discs (see diagram below) are welded into a single assembly using the most precise welding methods available to ensure the maximum level of strength and durability.

Rubber lagging is applied in our plant using a state of the art autoclave for maximum bond and total quality control.

## Six classes available to suit your specific needs:

Heavy Duty

Mine Duty

Pulp and Paper Mill Duty™

Quarry Duty

Extreme Duty

True Engineered Class

XT style hubs and bushings are standard

Keyless Locking Elements and QD Style

Stainless steel hubs and bushings in XT Style and QD Style

Lagging styles include:

- Standard Lagging in plain, herringbone/chevron, diamond, spiral or with machined finishes
- Ceramic Lagging for increased lagging life and more traction
- Replaceable Rim Lagging®

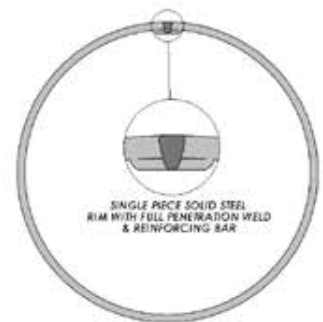

# Wing Pulleys

The engineered angle of our gussets creates the optimum angle to discharge material away from the pulley and belt and offers enhanced self cleaning ability over other designs.

## Six classes available to suit your specific needs:

Heavy Duty	Quarry Duty
Mine Duty	Extreme Duty
Pulp and Paper Mill Duty™	True Engineered Class

## Round Bar Better by Design

- Full 3/4" Thick Minimum Round Contact Bar Can Last 3X Longer
- Helps Prevent Wing Folding
- Round Bar Protects Belt Bottom Cover from Cuts and Tears
- Round Bar Increases Belt Fastener Life
- Self Cleaning Design Discharges Material Helping to Prevent Build Up
- Optional Wing Reinforcing Rings Available
- Spiral Wing Pulleys Available

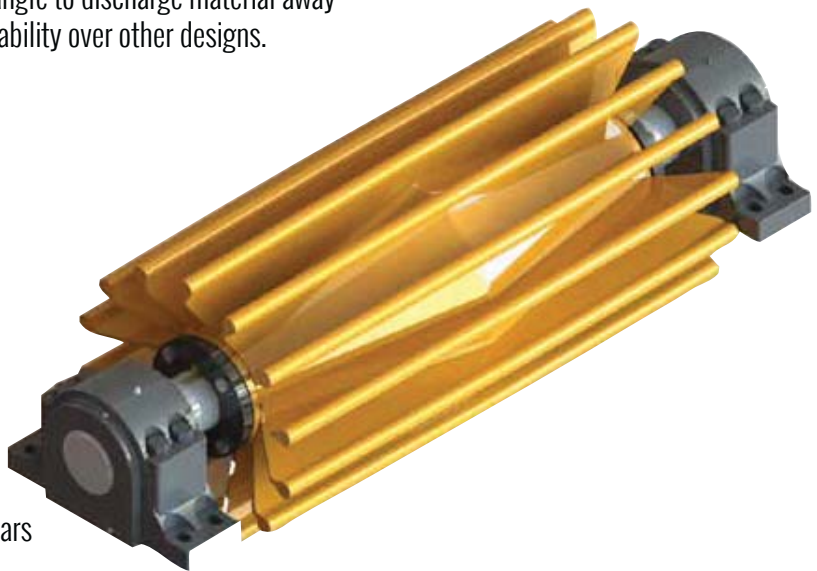

## Contact Bar Comparison

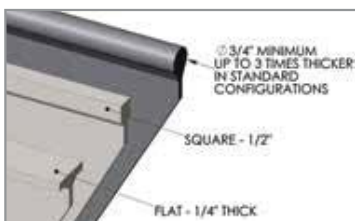

## Douglas Solid 3/4" Steel Round Bar Wing Tips Wear Longer and Retain Roundness.

Wears twice as long as other manufacturers flat bar or 1/4" round

Protects underside of belt from cuts, smoother running

Large pulley are fitted with 1" solid steel bars for long life



# Additional Pulley Systems

## The Vortex™ Spiral Clean Pulley

The Vortex Spiral Clean Pulley is an innovative concept in self cleaning pulley design. The cutting edge design is for harsh operating conditions and for those applications where uninterrupted operation is a must.

### Design features include:

- More efficient self cleaning ability than standard wing pulleys
- Smoother running, reduced vibration, improves sealing at transfer points, reduces the level of noise commonly associated with wing pulleys
- Spiral design aids in belt tracking by moving the belt gently from the center of the pulley to the opposing edges with equal force
- Unique continuous flight design prevents wing folding
- Patent pending design moves tramp material to the edge of the pulley and discharges it away from the belt
- Abrasion Resistant center and discharge assemblies standard
- XT style bushings standard. Keyless locking elements optional



## Integra™ Series Drum & Wing Pulleys

### Integral Bearing Pulleys Offer Many Performance Benefits

- May be used in all non-drive applications
- Available in drum, self cleaning wing and Vortex™ styles
- Available in Mine Duty & Extreme Duty™ Series
- Integral End disk eliminates chance of hub weld failure
- Piloted flanged bearing design simple to install, maintain & repair
- Sealed for life bearings equal less maintenance
- "Off the Shelf" bearing availability reduces down time and cost
- Up to 33% higher load ratings as a result of reduced bearing centers



## Ceramic Pulley Lagging

Douglas® Ceramic Pulley Lagging delivers substantially increased traction over conventional pulley lagging. Lagging compound features unique Kevlar® enhanced rubber formulation resulting in a tougher, longer lasting product. Durable ceramic tiles last longer than standard rubber lagging resulting in a reduction in the number of times the pulley must be changed over the life of the conveyor system. The ceramic tiles are bonded to the rubber on all four sides as well as the bottom.

- As much as twice the coefficient of friction over non lagged pulleys
- 38% ceramic contact surface with the belt (Medium Duty)
- As much as 50% higher coefficient of friction over standard rubber lagging
- Virtually eliminates belt slippage
- Improves belt tracking
- Easily sheds water and dirt
- Lower belt tension and less take-up weight increases life of components and belt



## Replaceable Rim Lagging®

Engineered sections are made for specific pulleys and effectively cover the pulley face in a protective shell of rubber and steel and are an ideal way to save money and time. Vulcanized in house using state of the art computer controlled autoclave. Standard RRL is manufactured with 1/2" thick 60-65 durometer SBR compound suitable for a wide variety of applications and is bonded to a 3/16" thick solid steel backing plate. ROLLED CROWN FACE is standard. Flat face is available. Diamond grooving is standard. Available in weld on and bolt on configurations.

Saves up to 70% on labor costs compared to other styles of replaceable lagging.

- No layout necessary to fit to existing pulleys
- No cutting necessary
- Available in weld on and bolt on styles
- Ceramic lagging available



REPLACEABLE RIM LAGGING® SECTION CHART										
Diameter	12	14	16	18	20	24	30	36	42	48
Weight P.L.L.	2.09	2.44	2.80	3.48	3.63	4.18	5.23	6.28	7.33	8.37
# of Segments Require	3	3	4	4	4	4	4	5	5	5

## Vulcanized Pulley Lagging

Douglas® Truck Tire Tuff™ Conveyor Pulley Lagging delivers increased traction and pulley life over non lagged pulleys. Increased traction between the pulley face and the belt bottom cover reduces belt slippage and helps to improve belt tracking. Vulcanized rubber lagging protects the pulley's face from wear and extends pulley service life. Lagging is applied in our plant for total quality control.

- As much as 50% increase in coefficient of friction over non lagged pulleys
- Protects pulley face from wear and extends pulley service life
- Herringbone and Diamond Grooves shed water and dirt promoting a self-cleaning effect
- Improves Belt Tracking



Standard Thicknesses	Standard Grooving Patterns	Standard Material	Standard Durometer	Special Durometers	Special Materials
1/4", 3/8", 1/2", 3/4"	Plain Wrap Impression*, Herringbone**, Diamond	SBR	60-65 Shore A	40, 80	MSHA, Nitrile, Neoprene, EPDM, SCOF, Tan Neoprene

# CEMA B, C, D & E Idlers

Douglas® manufactured Idlers are engineered for demanding CEMA B, C, D or E applications. Douglas idlers are available in a wide variety of configurations including: troughing, return, impact, rubber disc return, self aligning trough, self aligning return, scale quality and live shaft.

## Douglas idlers feature:

- Deep drawn steel end cap with metal outer seal provides excellent durability and protection
- Exclusive Triple Lip Polyurethane Contact Seal helps prevent bearing contamination
- The optional Defender™ Polymer Flinger helps prevent material buildup between the end of the roll and the frame as well as helps provide additional sealing in wet and corrosive applications
- CNC Machined, shouldered shaft helps ensure proper bearing alignment
- Rigid, self cleaning, welded steel frame with interchangeable mounting slots
- Reduced friction levels help conserve energy
- Meets or exceeds CEMA B, C, D & E idler ratings

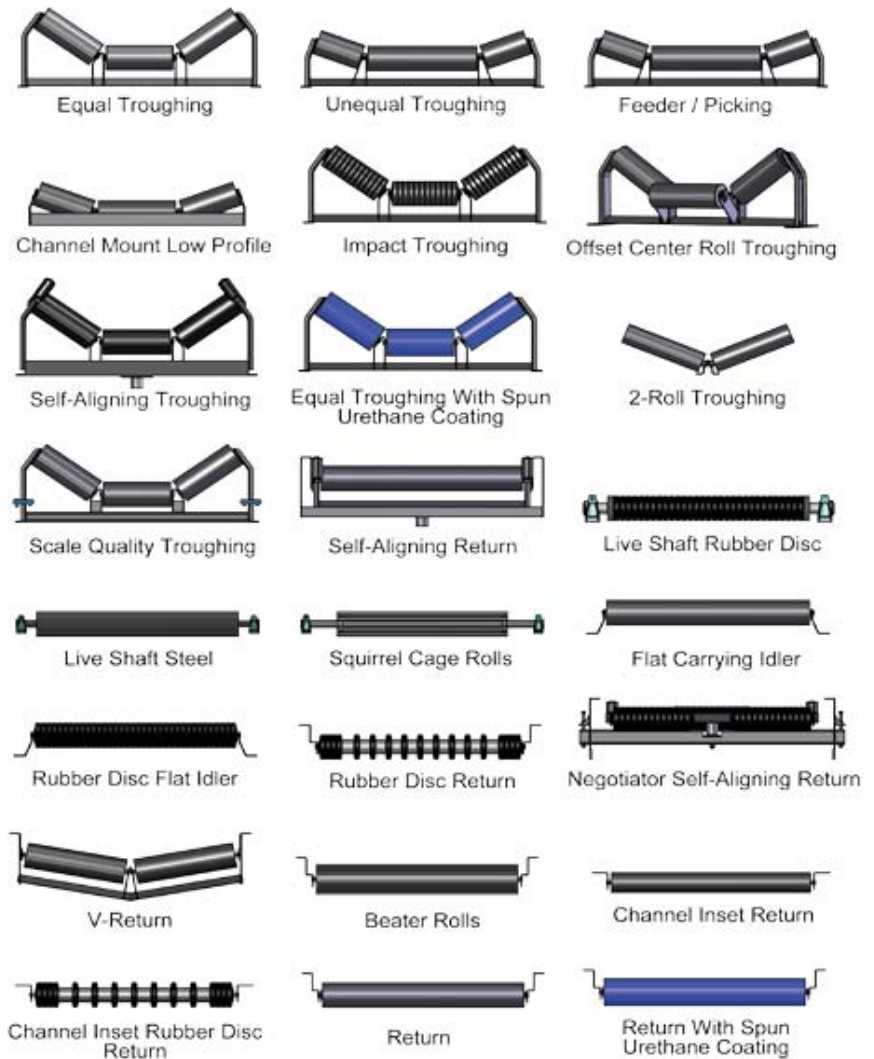

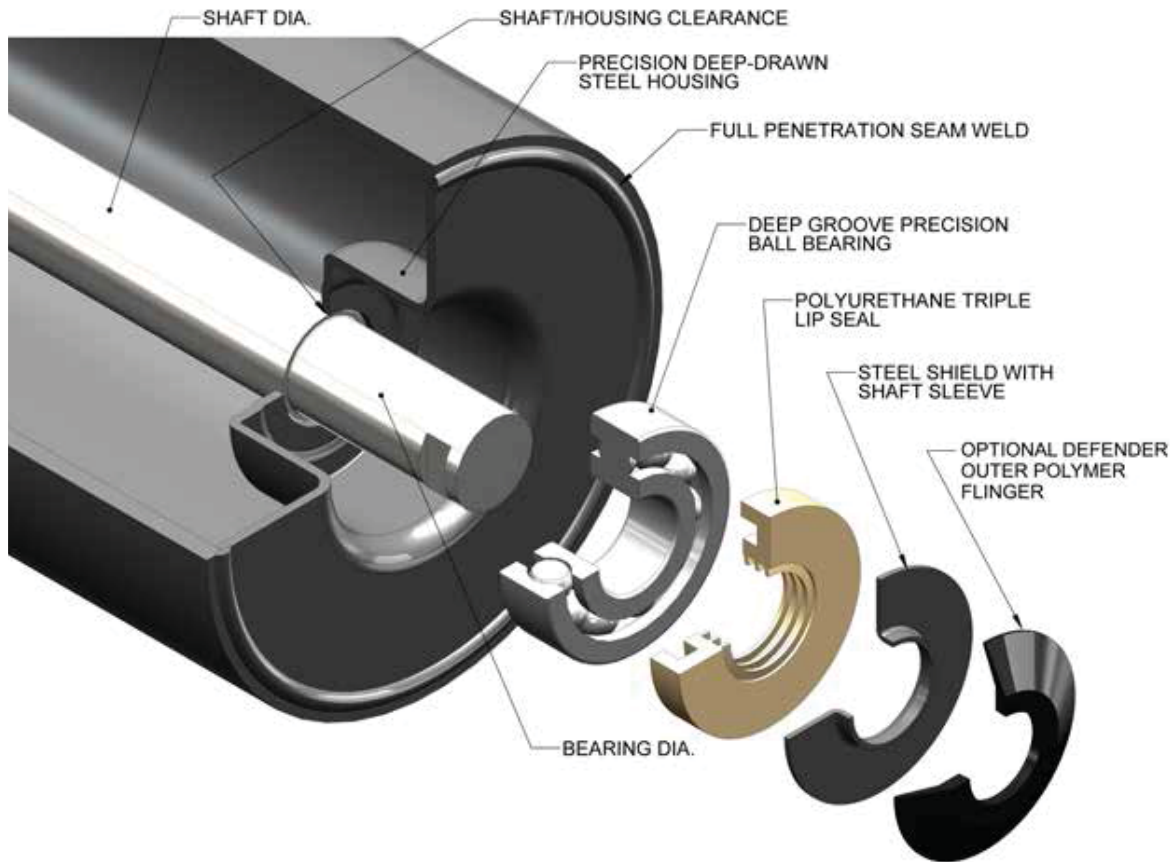

## Idler Features

- ① Foot Bracket - open design allows for single or double bolt hole mounting
- ② Self-cleaning base angle design
- ③ Die formed End Brackets provide clearance preventing material from being trapped between roll and end bracket
- ④ Bearing housings are welded 100% within the tubing O.D. (Welds do not contact the conveyor belt)
- ⑤ Retainer clip holds rolls within the frame and offers easy roll removal
- ⑥ Narrow roll gaps protect belt from excessive wear

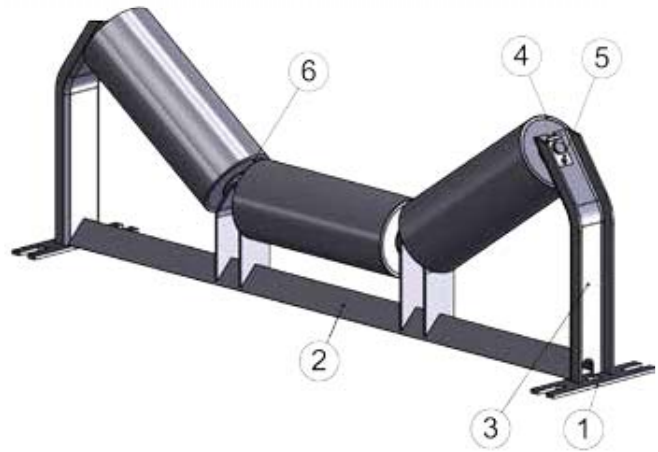

IDLER SPECIFICATIONS					
Class	Bearing Dia.	Shaft Dia.	Roll Dia.	Roll Thickness	Belt Width
CEMA-B	20mm	0.88"	4" & 5"	11 Ga	18" - 48"
CEMA-C	20mm	0.88"	4", 5", & 6"	11 Ga	18" - 60"
CEMA-D	25mm	1.19"	5" & 6"	9 Ga & 8 Ga	24" - 72"
CEMA-E	30mm	1.31"	6" & 7"	3/16" & 1/4"	36" - 96"



# Magnetic Separators & Pulleys

Douglas® magnetic separators are for use in helping separate tramp ferrous metals from conveyed material and are suspended above the belt. Magnetic pulleys are manufactured to CEMA standards and can be used in most any head pulley application.

## CEMA Class Permanent Magnetic Head Pulleys (PMG)

- Meets or exceeds CEMA/ANSI specifications
- Exclusive One Piece Rolled in Crown ensures consistent, proper belt tracking and tighter tolerances
- Remove potentially harmful tramp ferrous metal before it damages expensive processing equipment
- Crown face pulleys are furnished standard, flat face must be specified
- Douglas hubs and bushings are interchangeable with QD® or XT® style
- Stainless Steel Rim standard on all permanent magnetic pulleys

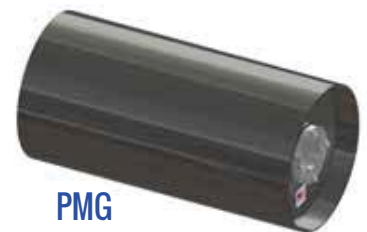

PMG

## Self Cleaning Permanent Magnetic Separator (CBM - Standard Power or CBX - Super Power)

- Automatically discharges tramp metal away from the conveyor
- Heavy grade structural steel frame complete with CEMA class lagged crown face head pulley, tail pulley and Slide Tube® belt take-ups
- Heavy duty rubber cover belt standard with hot vulcanized cleats
- Shipped complete, factory test run and ready for installation
- CLASS II shaft mount gear drive with TEFC motor



CBM



HMG

## Standard Manual Cleaning Permanent Magnetic Separators (HMG - Standard Power or XMG - Super Power)

- Manual cleaning of ferrous metal required
- Pivot arm or cleaning drawer available for easy cleaning
- Shipped complete and ready for installation



CBX

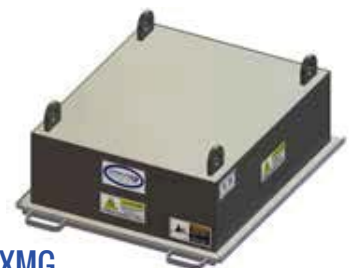

XMG



# Impact Beds & Bars

Douglas Impact Beds are engineered to protect the conveyor belt at key transfer point areas. They help to keep material on the belt where it belongs. Impact beds help to absorb shock loads and support the full width of the conveyor belt. They help to eliminate the cost of idler maintenance and failure. No more bent idler shafts and frames, or worn out rollers to replace.

## Titan™ Adjustable Impact Bed Assembly (IBA)

- Adjustable wing height easily changes from flat, 20° or 35° as needed
- Support arms adjustable from flat to 20° and 35°
- Easy installation, fold one side flat and slide under the belt
- 48" and 60" long beds and bars available
- Center impact rolls available (IRB)

## Titan™ Sectional Impact Bed Assembly (ISE)

- Reduce down-time with 3 easily removable sections while the conveyor belt is in place
- Fixed angles of 20°, 35° or 45° (specify at time of order)
- Removable sections allow simple bar replacement
- Sections allow for ease of installation in tight or out of the way applications
- 48" and 60" long beds and bars available
- Center impact rolls available (ISR)

## Impact Bed Bars (IBB) & T-Bolts (ITB)

- Replacement Impact Bars mount using field proven T-Bolt locking system
- Profiled leading edge helps increase service life of bars
- Anodized aluminum insert helps to prevent corrosion and ensure simple bar replacement
- Easily retrofits to many other manufacturer's impact bed assemblies
- 48" and 60" long bars available



# Take-Up Frames & Assemblies

**The Slide Tube™ (STT)** tough and dependable. The space saving design eliminates the need for additional take-up supports and allows for even load distribution.

**The Top Angle (TAF)** features a bolted top angle protects the threaded rod and allows for relatively simple bearing removal and replacement. Available with an optional channel or round bar bottom piece to accommodate SKF and Linkbelt or Dodge bearings respectively.

**The Center Pull (CPT)** is suitable to a wide variety of applications. The location of the threaded rod, in the center of the frame and bearing, helps to ensure even tensioning during operation. ACME™ all thread rod standard.

**The Heavy Duty Top Mount (HDT)** is designed for severe applications. The single piece heavy mounting plate is designed for a four bolt pattern style bearing but can be manufactured for two bolt bearings. The extra heavy welded steel construction helps ensure long-life and dependability in the roughest applications

**The Light Duty Top Mount (LDT)** is a two piece saddle design that is adjustable and can accommodate a wide range of 2 bolt pillow block ball bearings.

**The Wide Slot Side Mount (WST)** is designed to fit in very tight spaces. It mounts on the side of a conveyor frame or chute and uses wide slot ball bearings.

**The Scissors Pivot® Gravity Take-Up (STU)** is an engineered take-up system that incorporates a standard assembly consisting of 3 pulley assemblies, a lever arm and support chains (not shown). It automatically adjusts for belt stretch and is engineered for proper belt tension.

ACME™ all thread rod standard. <sup>1</sup>Bearings are provided separately.

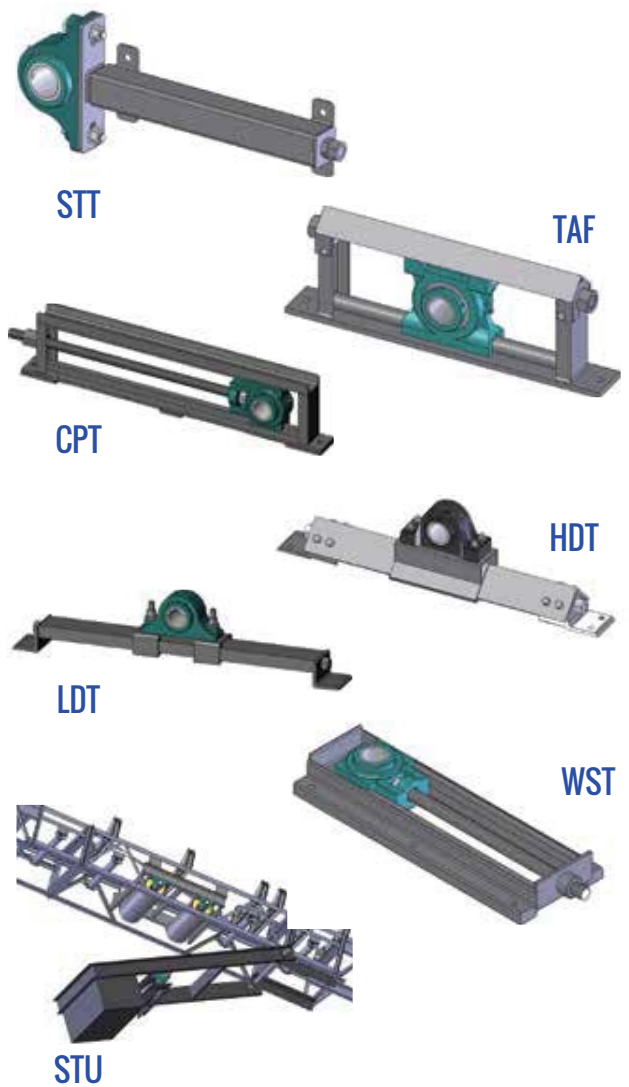

# Guardian<sup>3</sup> Premium Return Roll Guard

## DESIGN FEATURES

- Patented 180° UHMW Cage provides complete pinch point protection and catches the roll if it breaks away from the brackets.
- UHMW UV stable cage has increased slot sizes and new self cleaning slots in the bottom to help resist material build-up inside the guard.
- UHMW will not corrode, resists impact damage and wear from abrasion.
- UHMW side shield totally encapsulates the roll and snaps into place easily and securely using the provided heavy gauge steel mounting brackets.

## EASY INSTALLATION

Two options are provided for mounting: galvanized steel nuts, bolts and washers and optional pin and clevis for use on the back side of the roll to allow for easy maintenance and cleaning.

The end shield is snapped securely in place using the provided hanging brackets and integrated mounting system.

## EASY MAINTENANCE

The Guardian<sup>3</sup> requires little to no maintenance due to its unique, trouble free design. The wider self cleaning slots in the bottom of the guard help with self-cleaning ability and the deep reservoir design means less frequent cleaning if material build-up occurs. Clean out is a snap. Simply remove the fast action pins and allow the Guardian<sup>3</sup> to open to the cleaning position. The side shield is designed with a single large maintenance and viewing port to allow for greasing of idlers and roller inspection without the need to remove the side shield.

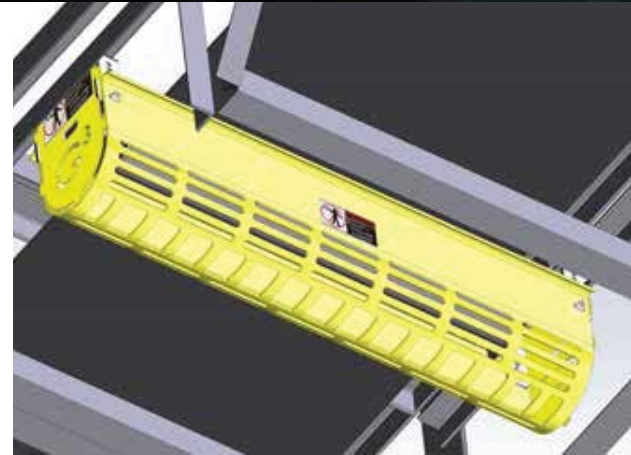

## COMPLIES WITH MSHA TITLE 30 CFR

- 56.14110 Flying or Falling Material
- 56.14112 Guard Construction
- 56.14107 Moving Machine Parts
- 5.1722 Mechanical Equipment Guards
- 7.400 Mechanical Equipment Guards

## 2-3/4 X 2 SLOTS DESIGNED TO ENHANCE SELF CLEANING

Meets OSHA requirements 1910.219 for mechanical power - transmission apparatus and 56.14107 for moving machine parts

U.S. Patent Number 6,318,545 B1

CEMA E VERSION AVAILABLE